

# BULLET TERMINAL

## Nominal 4.0mm dia. bullet male

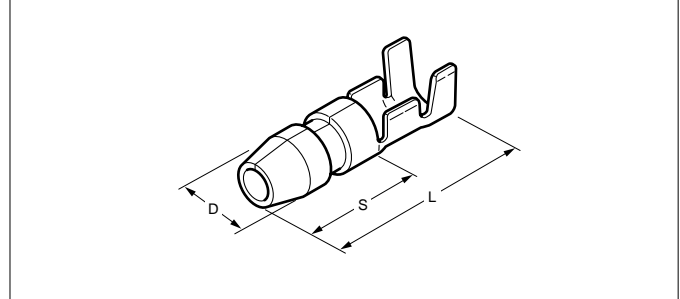

Recognized E60389

Certified LR20812

Model No.	Standard	Applicable wire			Material	Finish	Dimensions mm(in.)				Q'ty / reel
		mm <sup>2</sup>	AWG #	Insulation O.D. mm(in.)			D (dia.)	L	S	Material thickness	
SGM-51-4 SGM-51T-4	Recognized E60389 Certified LR20812	0.5 to 2.0	20 to 14	2.6 to 3.8 (.102 to .150)	Brass	— Tin-plated	3.55(.140)	15.9(.626)	7.3(.287)	0.5(.020)	5,000

## Nominal 4.0mm dia. bullet female

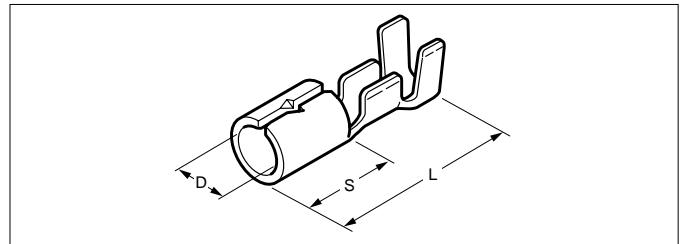

Recognized E60389

Certified LR20812

Model No.	Standard	Applicable wire			Material	Finish	Dimensions mm(in.)				Q'ty / reel
		mm <sup>2</sup>	AWG #	Insulation O.D. mm(in.)			D (dia.)	L	S	Material thickness	
SGF-41-4 SGF-41T-4	Recognized E60389 Certified LR20812	0.5 to 1.25	20 to 16	2.6 to 3.5 (.102 to .138)	Brass	— Tin-plated	3.5(.138)	17.5(.689)	6.4(.252)	0.32(.013)	7,500

## Nominal 5.0mm dia. bullet male

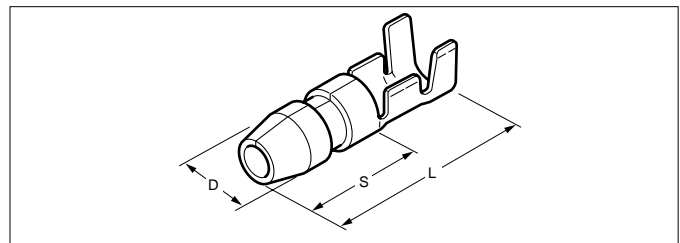

Recognized E60389

Certified LR20812

Model No.	Standard	Applicable wire			Material	Finish	Dimensions mm(in.)				Q'ty / reel
		mm <sup>2</sup>	AWG #	Insulation O.D. mm(in.)			D (dia.)	L	S	Material thickness	
SGM-21-5 SGM-21T-5	Recognized E60389 Certified LR20812	0.3 to 0.75	22 to 18	1.7 to 2.9 (.067 to .114)	Brass	— Tin-plated	3.96(.156)	17.5(.689)	8.9(.350)	0.5(.020)	5,000
SGM-51-5 SGM-51T-5	Recognized E60389 Certified LR20812	0.5 to 2.0	20 to 14	2.6 to 3.8 (.102 to .150)							

# BULLET TERMINAL

## Nominal 5.0mm dia. bullet female

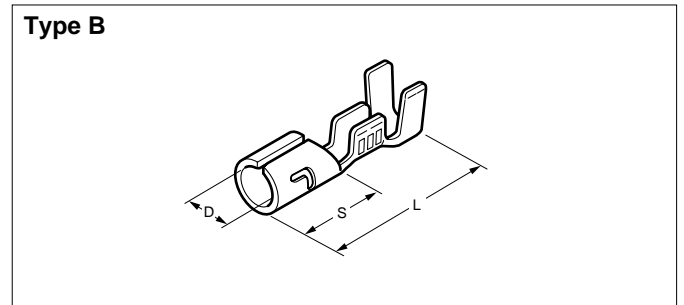
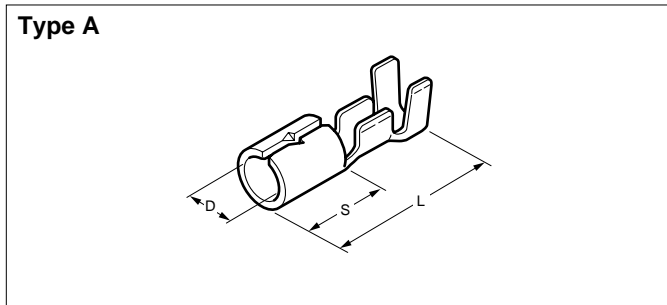

Recognized E60389

Certified LR20812

Model No.	Standard	Applicable wire			Material	Type	Finish	Dimensions mm(in.)				Q'ty / reel	
		mm <sup>2</sup>	AWG #	Insulation O.D. mm(in.)				D (dia.)	L	S	Material thickness		
SGF-21-5		0.3 to 0.75	22 to 18	1.7 to 2.9 (.067 to .114)	Brass	A	—	3.96(.156)	17.5(.689)	6.4(.252)	0.4(.016)	5,000	
SGF-21T-5							Tin-plated						
SGF-51-5		0.5 to 2.0	20 to 14	2.6 to 3.8 (.102 to .150)			B						—
SGF-51T-5													Tin-plated
SGF-51T-5A													

Note: Type B.....low-insertion force type.

## Applicator for the semi-automatic press AP-K2N

Contact	Crimp applicator MK-L	
	with safety cover	without safety cover
SGF-21(T)-5	APLMK SGF21-5	APLNC SGF21-5
SGF-41(T)-4	APLMK SGF41-4	APLNC SGF41-4
SGF-51(T)-5	APLMK SGF51-5	APLNC SGF51-5
SGF-51(T)-5A	APLMK SGF51-5	APLNC SGF51-5
SGM-21(T)-5	APLMK SGM21-5	APLNC SGM21-5
SGM-51(T)-4	APLMK SGM51-4	APLNC SGM51-4
SGM-51(T)-5	APLMK SGM51-5	APLNC SGM51-5

- \* Contact JST if Lead-Free product is required.
- \* Refer to "General Instruction and Notice when using Terminals and Connectors" at the end of this catalog.
- \* Contact JST for details.